

Cold Deck

Canopy and Shelf Lights and Retrofit Kit

Installation Guide for 701940

General Information

- Cold Deck LED lighting systems are intended for use inside of commercial refrigerated display merchandisers for food zone, splash zone, and non-food zones only.
- Cold Deck LED lighting systems are Class 2 low voltage luminaires intended to replace standard fluorescent fixtures in refrigerated multi-deck merchandisers after electronic ballasts have been replaced by SloanLED 24 VDC power supplies.
- **WARNING – Risk of Fire or Electric Shock. Not for direct replacement of Fluorescent Lamps. Use only with SloanLED Power Supply (P/N 701895-24C or 701895-24W). See installation instructions.**
- Use only a damp cloth and mild cleaning agent to clean Cold Deck luminaires.
- The Cold Deck Retrofit Kit (retrofit kit), in the context of this guide, is all of the component parts needed, including these installation instructions, for a retrofit luminaire conversion.
- Retrofit luminaire conversion is the act of modifying, with the parts provided in the retrofit kit, a luminaire already manufactured and in service in order to convert the luminaire to a LED light source from its original light source. The refrigerated display merchandiser is considered the luminaire in this context, and the complete retrofit kit is assembled during the audit of each merchandiser, on site, prior to installation.

Tools and Accessories Recommended

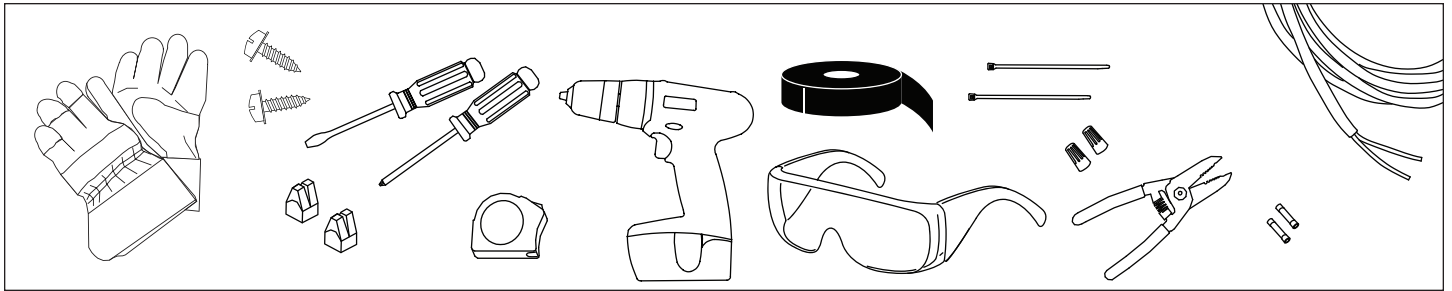

Do not remove existing primary merchandiser wiring.

Tools and connections shown are for primary connections: Gloves, safety glasses, flat and Phillips head screwdrivers, screws, standard drill, measuring tape, electrical tape, wire strippers, twist-on or push-in UL Listed wire connectors for up to four (4) 18 AWG conductors, tie-wraps, and UL Listed 18 gauge wires (multiple colors such as white, black, blue, and red are useful to avoid confusion, but not required).

Items Provided

1. Cold Deck Canopy Light
2. Cold Deck Shelf Light
3. Stand-off Clips
4. Power Supplies
5. Retrofit Sticker
6. Dimming Controller (optional)
7. Motion Sensor (optional, Wide Angle shown)
8. Clip Spanner Wrench
9. Locking Clips

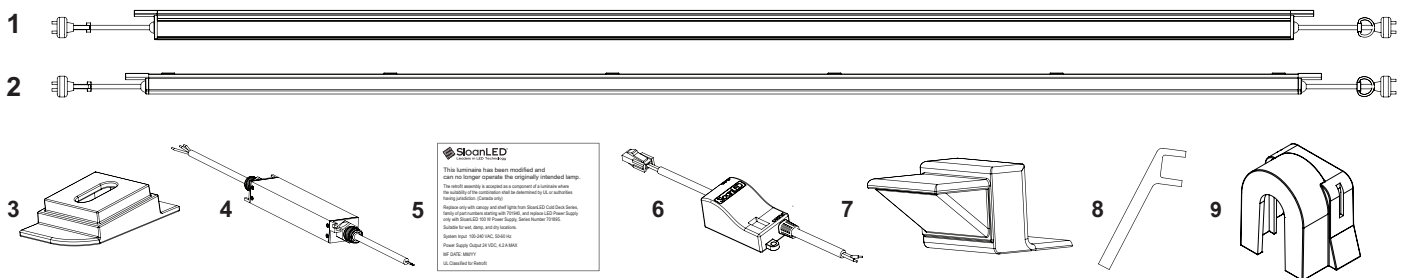

Check to ensure correct count of bill of materials prior to removing installed lamps and ballasts.

NOTE: Cold Deck Canopy Lights are intended to be used in the canopy of multi-deck merchandisers only. Any attempt to install these luminaires into the trough or under the shelving may cause damage to the merchandiser and/or performance may not match literature specifications. Cold Deck Shelf Lights may be installed under shelving.

Cold Deck

Canopy and Shelf Lights and Retrofit Kit

Installation Guide for 701940

Luminaire Directivity

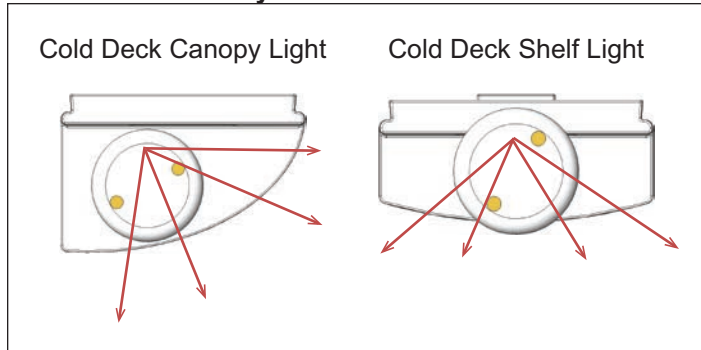

Luminaire Placement

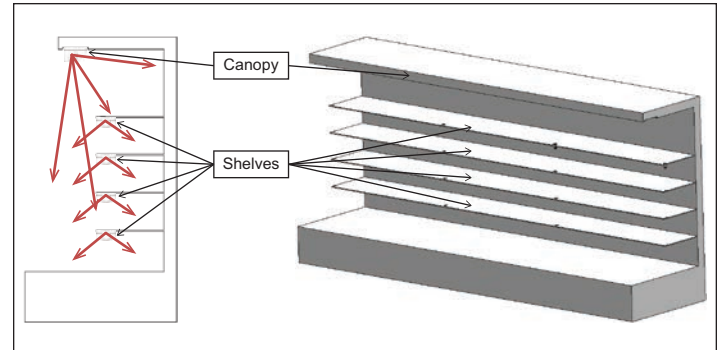

For Your Safety

- Read and understand all instructions in this installation guide prior to retrofitting any refrigerated display merchandiser.
- Read and observe all NOTES, CAUTIONS and WARNINGS shown throughout these instructions.
- Installation must be performed by trained service personnel only.
- The Cold Deck Retrofit Kit (retrofit kit) is UL Classified; the luminaires are UL Listed for dry, damp, and wet locations, as well as food zone, splash zone, and non-food zones in commercial refrigerated display merchandisers.
- Gloves and safety glasses should be worn at all times during installation. Safety goggles are recommended during power supply installation.
- Retrofit kit electrical input specifications: Up to 1.4 A Max, 100-240 VAC.
- Retrofit kit electrical output specifications: Up to 4.2 A, 100 W, 24 VDC, Class 2 circuit.
- The retrofit kit is accepted as a component of a luminaire where the suitability of the combination shall be determined by CSA or authorities having jurisdiction (Canada only).
- Do not make or alter any open holes in an enclosure of wiring or electrical components during installation.
- Only open holes indicated in the photographs and/or drawings may be made or altered as a result of the retrofit kit installation. Do not leave any other open holes in an enclosure of wiring or electrical components.
- WARNING – To prevent wiring damage or abrasion, do not expose wiring to edges of sheet metal or other sharp objects.
- WARNING – Risk of fire or electrical shock. Luminaire wiring, LED Driver, or other electrical parts may be damaged when drilling for installation of the retrofit kit. Inspect wiring and components for damage.
- WARNING – Risk of fire or electrical shock. Install this retrofit kit only in the luminaires that have the constructional features and dimensions shown in the photographs and/or drawings.
- WARNING – Risk of fire or electrical shock. Install this retrofit kit only in luminaires used in refrigerated display merchandisers that have the constructional features and dimensions shown in the photographs and/or drawings.
- INSTALLATION OF THIS RETROFIT ASSEMBLY REQUIRES A PERSON FAMILIAR WITH THE CONSTRUCTION AND OPERATION OF FLUORESCENT LIGHTING LUMINAIRE ELECTRICAL SYSTEMS AND THE HAZARD INVOLVED.
- WARNING – Risk of fire or electrical shock. Retrofit kit installation requires knowledge of fluorescent lighting luminaire electrical systems. If not qualified, do not attempt installation. Contact a qualified electrician.
- Install to NEC, state, and local regulations.
- Once conversion is complete, adhere sticker provided that says “This luminaire has been modified and can no longer operate the originally intended lamp” near the lamp on/off switch located in the refrigerated display merchandiser.

Cold Deck Canopy and Shelf Lights and Retrofit Kit

Installation Guide for 701940

Preparation for Installation

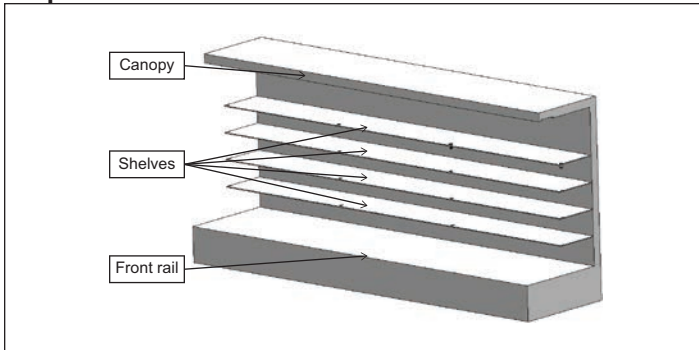

CAUTION: All ballasts must be located and removed during the retrofit procedure. If all ballasts cannot be located, stop the retrofitting procedure and contact the OEM for assistance.

1. **Warning: Risk of electrical shock.** Locate main circuit breaker panel, de-energize, and perform lockout/tagout prior to retrofitting merchandiser. All primary wiring must be done by a licensed electrician.
2. Prior to beginning work, perform an audit and visual inspection of refrigerated display case to be retrofitted. Locate and note original equipment manufacturer's (OEM) part number and serial number. If possible, obtain and review OEM's set up and installation manual, specifically the sections that relate to the location of the power switch, the number and location of all fluorescent lamp holders and ballasts, and the wiring diagram.

3. As required, remove fluorescent bulbs and reflectors (if present) from the canopy, under the shelves, and inside the front rail. Dispose of bulbs per local, state, or federal regulations. Refer to <http://lampprecycle.org> for guidance.
4. Remove electrical raceway cover. With some merchandisers, raceway cover may be the entire canopy panel. Refer to the OEM's manual for instructions on how to access existing ballasts for canopy and shelf lights.

CAUTION: The weight of the canopy panel and bundled wiring may cause the panel to swing down upon removal of the final screw. Dust and debris may have accumulated on the panel since original installation. Safety goggles are recommended.

If no OEM documentation can be obtained, the case must be visually inspected prior to installation. Locate all pairs of fluorescent lamp holders and note number and locations. Lamp holders are normally in the canopy, under the shelves, and in the front rail. A typical 12' (3600 mm) merchandiser will have between 15 and 27 pairs of lamp holders, and will have five (5) to nine (9) ballasts to power them (in a ratio of 3:1).

Bypass Ballasts and Install Power Supplies

5. Remove installed ballasts and install appropriate number of power supplies based on respective number of Canopy and Shelf Lights.

NOTE: Only one (1) Canopy Light required to replace up to three (3) fluorescent lamps per 4' (1200 mm) section of canopy. Reference Table 1 for number of power supplies required.

To mount power supplies, choose a central location in the electrical raceway away from any other heat generating element. Mount power supplies

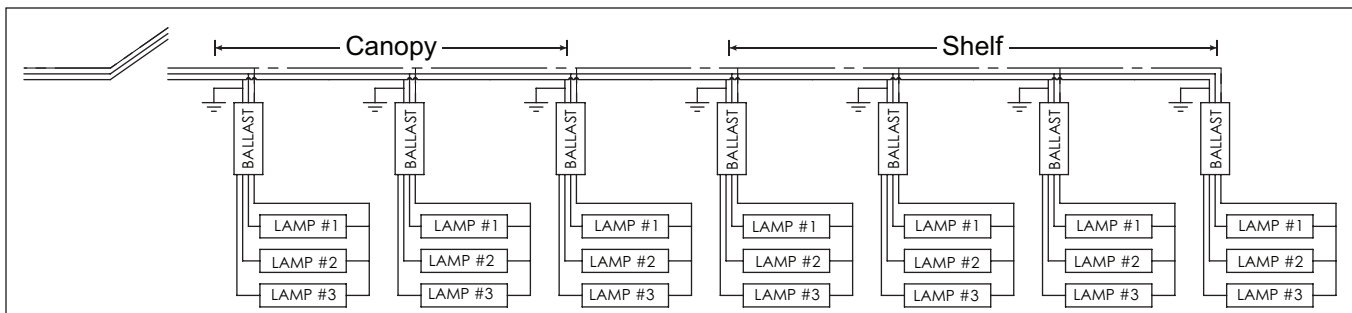

Typical wiring diagram for a 12' (3600 mm) multi-deck merchandiser before retrofit conversion, with three (3) rows of canopy lamps and lamp holders along with four (4) rows of three (3) shelves.

Cold Deck

Canopy and Shelf Lights and Retrofit Kit

Installation Guide for 701940

Bypass Ballasts and Install Power Supplies *cont'd*

CAUTION: Power supplies should not be mounted near any other heat generating element. Mount each power supply with two (2) self-drilling/self-tapping screws through tabs in both end caps.

6. Mount power supplies near the ballasts that will be bypassed and removed.

Typically, two (2) power supplies are needed to power a 12' (3600 mm) merchandiser consisting of three (3) 4' (1200 mm) Canopy Lights and twelve (12) 4' (1200 mm) Shelf Lights. Refer to table 1 for the number of power supplies required based on on-site configurations.

7. Connect 120/240 VAC 50-60 Hz to power supply for the Canopy and Shelf Lights, (refer to wire description on power supply label). Use UL Listed twist-on or push-in connectors for connections. Follow connector manufacturer's instructions.

NOTE: PRIMARY WIRING CONNECTIONS: AC Neutral to Power Supply White; AC Line to Power Supply Black; Earth Ground to Power Supply Green.

Table 1- Cold Deck lights per power supply

	Canopy	Shelf
4' (1200 mm)	4	12
3' (910 mm)	6	16

NOTE: Three (3) 4' (1200 mm) Shelf Lights may be substituted for every Canopy Light.

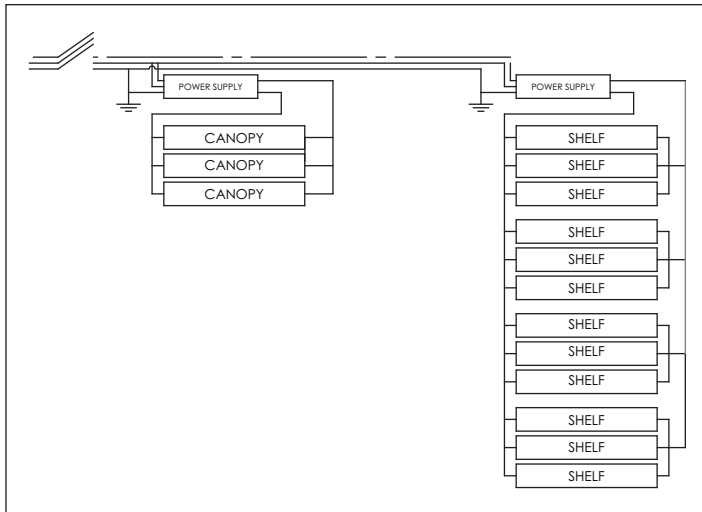

Typical wiring diagram for a 12' (3600 mm) retrofitted multi-deck merchandiser with three (3) rows of Canopy Lights installed and four (4) rows of three (3) shelves with 12 Cold Deck Shelf Lights. In this scenario, lights are assumed to be standard 4' (1200 mm).

Cold Deck

Canopy and Shelf Lights and Retrofit Kit

Installation Guide for 701940

Bypass Ballasts and Install Power Supplies *cont'd*

NOTE: If additional wire required, use UL Listed 18 AWG wire and UL Listed twist-on or push-in wire connectors to connect supplemental wire to the utility line wire as needed.

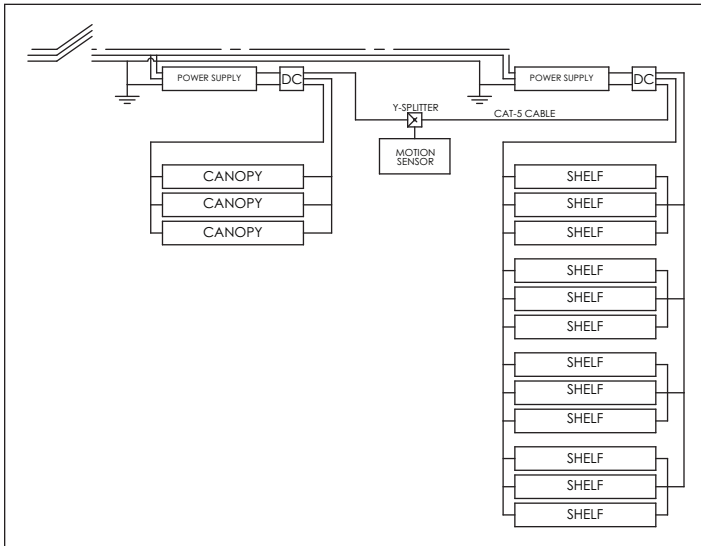

8. Installation with optional Dimming Controller and Motion Sensor. The Dimming Controller is connected to the secondary side of the power supply. Cat 5 cable may be routed behind electrical raceway and outside of merchandiser as required.

CAUTION: Primary and secondary wiring needs to be physically separated inside of the raceway.

NOTE: One (1) Dimming Controller required per power supply.

WARNING: RISK OF ELECTRICAL SHOCK. Unused wires on Cold Deck Canopy and Shelf Lights must be individually capped off or removed.

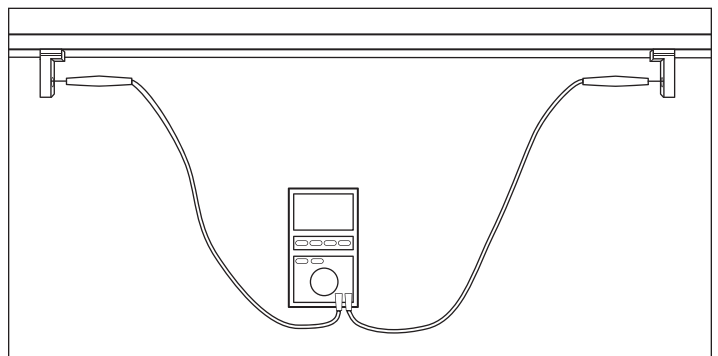

9. Before closing the canopy raceway, test lamp holders for electrical shock hazard. Ensure that no unused wires are exposed after installing the power supplies. Re-energize the system via the power switch. Using a voltmeter or multimeter, check for voltage, both AC and DC, between fluorescent lamp holders for all shelf and canopy lights. Measurements should read 24 VDC \pm 0.25 V and there should be 0 VAC \pm 1 VAC.

NOTE: If AC voltage measured, line voltage is present on the low voltage side of system. De-energize system and troubleshoot accordingly.

10. Replace electrical raceway cover. Ensure all wires are clear of pinching; pinched wires will cause the panel to close improperly. Use tie-wraps to help organize and secure wires if necessary. Replace screws removed in Step 4 of this installation guide.

Cold Deck

Canopy and Shelf Lights and Retrofit Kit

Installation Guide for 701940

Canopy Light Installation

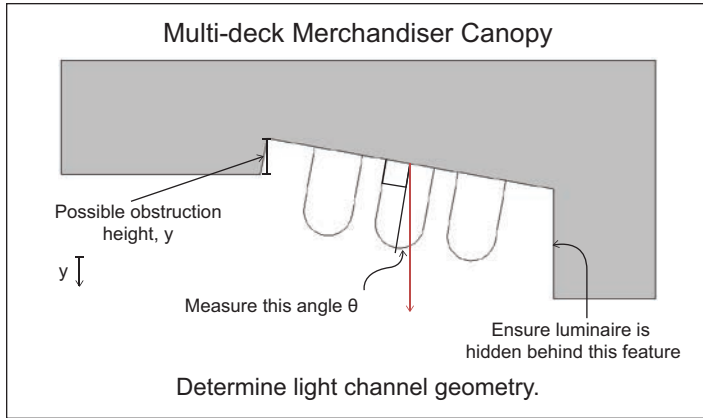

11. Determine angle of light channel. Using a plumb-bob or other method, determine the angle of the inclination and record. Check for features on the light channel which may cause an obstruction of light pattern from the luminaire. If an obstruction is present, measure height and note. Ensure that luminaire can be installed at this height while remaining behind canopy fascia after installation.

Table 2

# of alternating Stand-off Clips	# of inclining progressive Stand-off Clips	Angle measured, θ	Stand-off height, y
0	1	5°	0.25"
0	2	10°	0.50"
2	0	0°	0.50"
4	0	0°	1.00"
2	2	10°	1.00"

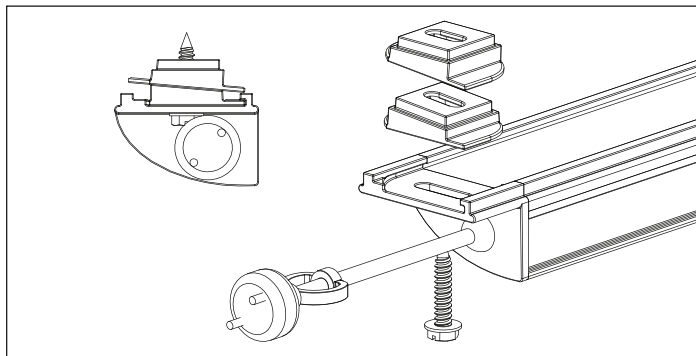

13a. Attach Stand-off Clips as shown in diagram. Use appropriate length (based on number of Stand-off Clips required), self-drilling/self-tapping, #8 or #10, pan or hex head screws. Stainless steel screws are recommended.

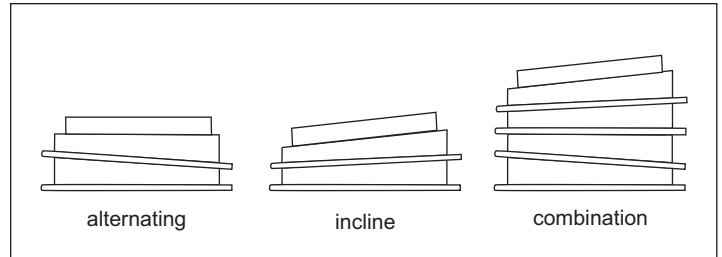

12. Determine the proper configuration of the angled Stand-off Clips needed for given merchandiser construction. Each angled Stand-off Clip imparts a 5° angle on the Canopy Lights. If clips are stacked facing the same way, the angle progressively increases with each clip in 5° increments. If clips are stacked in an alternating orientation (front to back), the total angle that the canopy is held at zero and the clips become a 0.5" (12.7 mm) stand-off.

NOTE: Configurations are additive.

NOTE: If the light channel is angled, a pilot hole should be marked and drilled prior to drilling the screws in. Canopy Lights may have pilot holes drilled prior to closing the light channel if required.

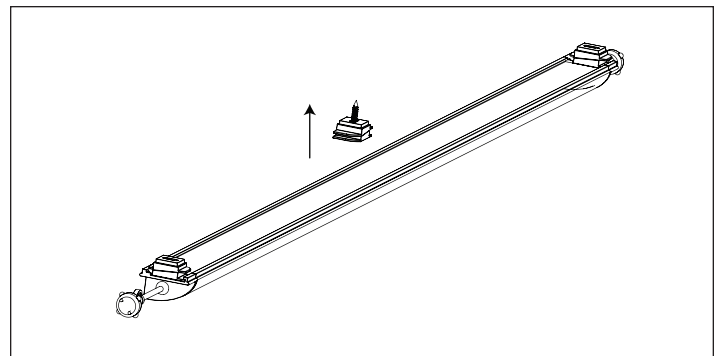

13b. Affix appropriate configuration of Stand-off Clips for centerline-line mounting of Canopy Light.

Cold Deck

Canopy and Shelf Lights and Retrofit Kit

Installation Guide for 701940

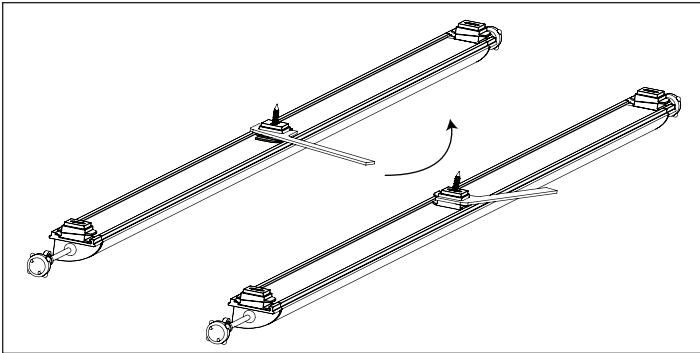

13c. Lock Canopy Light into place using Clip Spanner Wrench.

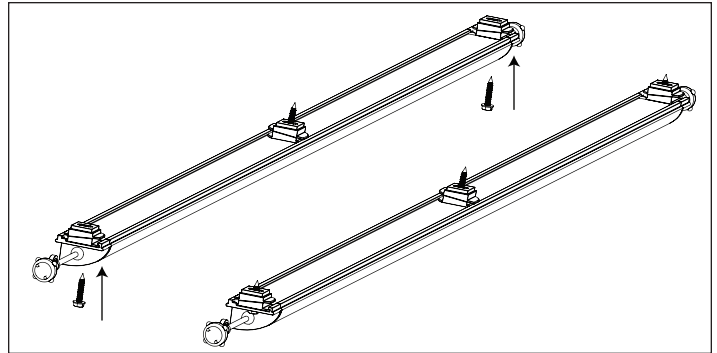

13d. Secure Canopy Light by installing appropriate length mounting screws through end cap mounting slots.

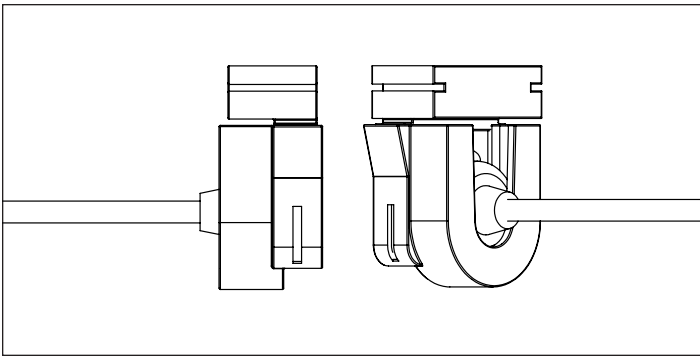

For part numbers ending in X1, proceed to step 14a, for part numbers ending in X2, proceed to 14b.

14a. Connect dongles to fluorescent lamp holders. Select appropriately sized Locking Clips, slide over lamp holders and secure with lamp holder bands as required. (Proceed to step 15)

14b. Follow all previous sections of this installation guide. Remove the electrical raceway that houses the incumbent lamp holder and remove from raceway. Cut wires from base of lamp holder and connect appropriate wires to flying lead from LED luminaire using twist-on or push in UL listed wire connectors. Replace raceway in its original location. *NOTE: Make all secondary connections inside of raceway.* (Proceed to step 15)

Shelf Light Installation

15. Place Shelf Lights. The Shelf Lights initial method of attachment is via magnets, with the primary method of securement via screws through the end caps. Place Shelf Lights on flat surface that fully engages as many magnets as possible. Shelf Lights can be placed up to 4" (100 mm) away from the fluorescent lamp holders. Mechanically fasten luminaires into place by screwing through the holes in the end caps using an appropriate fastener. Reference Canopy Light installation instructions.

NOTE: For the most secure connection between dongle and lamp holder, coil the cable lead into a spiral or circle as much as possible.

Turn on the System

16. Energize main circuit breaker. Confirm proper luminaire operation.

Ordering Replacement Luminaires

Example: 701940-4WC4X1

701940-

Color Temperature

Code	Description
2W	2700 K
3W	3500 K
4W	4100 K

Type

Code	Description
C	Canopy
S	Shelf

Length

Code	Description
3	3'
4	4'

Configuration

Code	Description
X1	With dongle
X2*	Special order

* To order parts in X2 configuration, contact customer service.

Additional Parts

Description	Part Number
Power Supply, 100 W	701895-24C
Stand-off Clips	401091
Clip Spanner Wrench	401368

Cold Deck

Canopy and Shelf Lights and Retrofit Kit

Installation Guide for 701940

Dimming Controller Settings

Merchandising Settings (Brightness)

Selectable Duty Cycle output via SW1 and SW2
(Brightness level when shoppers in area)

Default setting from factory is Standard

SW1	SW2	SW3	SW4	Brightness level
OFF	OFF	X	X	N/A
ON	OFF	X	X	Energy Saver
OFF	ON	X	X	Standard
ON	ON	X	X	MerchandiserMax

Dimming Settings (Dimming)

Selectable Duty Cycle output via SW3 and SW4
(Brightness level when no shoppers in area)

Default setting from factory is 25%

SW1	SW2	SW3	SW4	Percent of full brightness
X	X	OFF	OFF	0%
X	X	ON	OFF	12.5%
X	X	OFF	ON	25%
X	X	ON	ON	50%

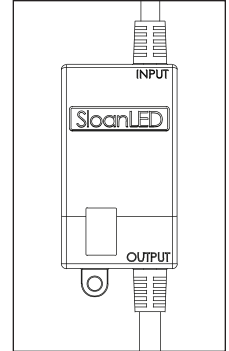

Dimming Controller
701890-PWR

Removal Instructions

1. De-energize system as outlined in the Preparation for Install section on Page 3 of this installation manual and undo electrical connections to LED lights.
2. Grab light with a free hand.
3. *For Canopy Lights:* Using wrench provided, disengage center mounting clip. Using appropriate sized screwdriver or nut driver, remove mounting hardware and remove luminaire from merchandiser.
For Shelf Lights: Using wrench provided, disengage center mounting clip. As needed, remove mounting hardware. Disengage mounting magnets from under-shelf and remove from merchandiser.
4. Repeat process for the remaining lights. Make sure to continually support the LED lights with a free hand during removal.
5. Open electrical raceway cover and remove power supplies.
6. Cap or remove all primary wires.

Cold Deck is covered by US and foreign patents pending.



UL Retrofit file number: E355292
UL Low Voltage Luminaires and Fittings file number: E329727
UL NSF/ANSI 2 file number: SA33165